



Installation Guide

DISCLAIMER

No part of this publication may be stored, reproduced or copied without prior written permission from IMO Precision Controls Ltd. The material furnished in this document is believed to be accurate and reliable however, IMO Precision Controls Ltd assumes no responsibility for the use of this material. IMO Precision Controls Ltd reserves the right to make changes to the information contained at any time without prior notice. All products and company names mentioned in this manual are trademarks or registered trademarks of their respective holders. The information contained herein is subject to change without prior notice for improvement.

FCC

This equipment has been tested and verified to be in compliance with the limits for FCC CFR47 part 15.107 Class B - Conducted Emissions and FCC CRF47 Part 15.109 Class B - Radiated Emissions, to provide reasonable protection against harmful interference for unlicensed premises. This equipment generates and can radiate radio frequencies, and if not installed in accordance with the instructions, may cause interference with radio communications; should such interference occur then consider relocation of the product in order to increase the separation between the equipment.

Alterations not approved by the compliance authority may void the user's authority to operate this equipment.

CONTACT DETAILS

Please contact the below concerning technical questions about this product:-

| | | |
|-------------------------|---------------------|---------------------------|
| United Kingdom | 020 8452 6444 | imo@imopc.com |
| Australia / New Zealand | 08 9302 5246 | support@imopacific.com.au |
| Canada | 905 799 9237 | imo-ca@imopc.com |
| USA | 678 679 7110 | imo-usa@imopc.com |
| France | 0800 912 712 | imo-fr@imopc.com |
| Italy | 800 930 872 | imo-it@imopc.com |
| South Africa | 021 551 1787 | info@imopc.co.za |
| Rest Of The World | +44 (0)20 8452 6444 | imo@imopc.com |

SAFETY SYMBOLS

Please contact the below concerning technical questions about this product:-



Warning - Failure to heed this the information indicated by this symbol may lead to dangerous conditions, possibly resulting in death or serious bodily injury.



Caution - Failure to heed this the information indicated by this symbol may lead to dangerous conditions, possibly resulting in minor or light bodily injuries and/or substantial property damage.



Information - Denotes important information about safety issues.



Note - Denotes additional information.

SAFETY INSTRUCTIONS



The FireRaptor is an electrical product and should only be installed by a suitably qualified person, in accordance with local regulations.



When modifying an existing installation, isolate the inverter from the PV array by turning OFF the DC isolator / switch disconnect or turn OFF the inverter and the AC switch.



PV Panel input and output connectors are not environmentally sealed until they are mated. Disconnected connectors should be plugged into an appropriate mating part or used with suitable watertight caps.



FireRaptor DC input and output connectors are not environmentally sealed until they are mated. Disconnected connectors should be plugged into an appropriate mating part (Tyco 282104-1 & 2pcs 282081-1 provided in FRS-ESW1/ FRS-ESW1-F / FRS-ESW1-K / FRS-ESW1-FK) or used with suitable watertight caps.



Incorrect connections to the FireRaptor may cause failure.

CAUTIONS



Installation of the IMO FireRaptor without ensuring compatibility of the module/inverter connectors with the FireRaptor connectors may be unsafe and cause operational problems. For mechanical compatibility of the modules/inverter and the FireRaptor, use identical connectors from the same manufacturer on both the FireRaptor and modules, or obtain verification that the connectors to be used are compatible.



If the IMO FireRaptor is to be mounted directly to the PV frame or module, obtain guidance from the module manufacturer regarding its location and also verify the impact on the module warranty.

INTRODUCTION

The IMO Precision Controls FireRaptor product is a Rapid Shut Down System for connection to PV panel arrays in order to achieve compliance to 2014 NEC 690.12 and the forthcoming 2017 NEC 690.12.

The FireRaptor automatically shuts down array output to the PV inverter when it detects a temperature in excess to 85°C (FRS-01) and 92°C (FRS-02).

The FireRaptor can be installed without any set-up and with any string inverter as its functionality is completely independent. "Plug & Play" style installation using industry standard connectors makes the IMO FireRaptor suitable for new installations as well as retro-fit; and its mains powered independent DC power supply and emergency switch unit allows flexibility for positioning for user convenience giving Manual Emergency Shutdown, as well responding to local or area grid shutdown.

PARTS

| | |
|------------|---|
| FRS-01 | FireRaptor Rapid Shutdown System Unit |
| FRS-02 | FireRaptor Rapid Shutdown System Unit with Fire Monitoring & Integration Options |
| FRS-ESW1 | Emergency Rapid Shutdown Switch Unit (for FRS-01) - includes 24 VDC power supply |
| FRS-ESW2 | Emergency Rapid Shutdown Switch Unit (for FRS-02) - includes 24 VDC power supply |
| FRS-ESW1-K | Emergency Rapid Shutdown Switch Unit with Key Lock (standard key) for FRS-01 - includes 24 VDC power supply |
| FRS-ESW2-K | Emergency Rapid Shutdown Switch Unit with Key Lock (standard key) for FRS-02 - includes 24 VDC power supply |
| FRS-ASW1 | Auxiliary Emergency Rapid Shutdown Switch Unit (excludes 24 VDC power supply) |
| FRS-ASW1-K | Auxiliary Emergency Rapid Shutdown Switch Unit with Key Lock (excludes 24 VDC power supply) |

INSTALLATION & CONNECTION

One FireRaptor will control two solar panels and for compliance with 2017 NEC it should be mounted within the array boundary of the two panels, where the two panels are no greater than 1' (foot) /30cm apart from each other.

Determine the mounting location of the FireRaptor (FRS-01 / FRS-02) and fix as shown below.

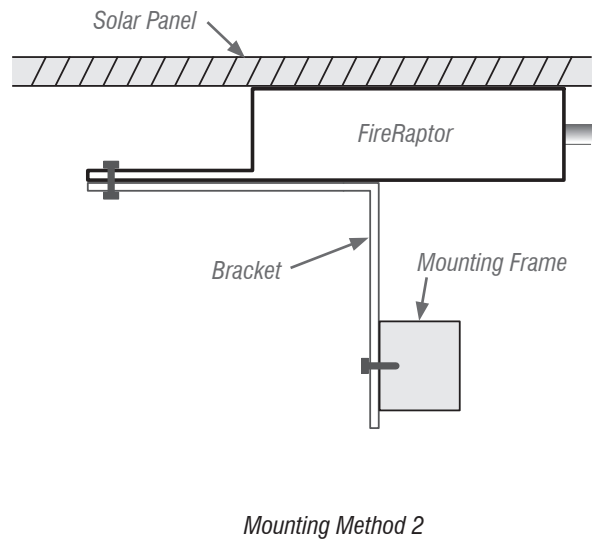
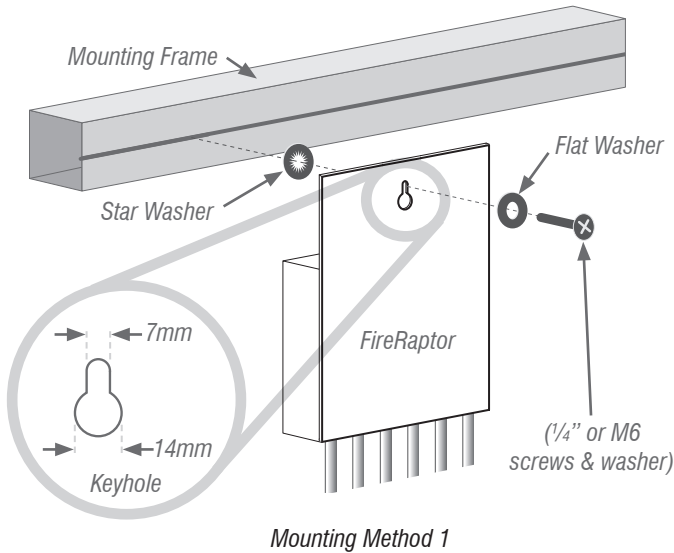

Do not drill through the FireRaptor as this will damage the unit and prevent operation.

Mounting Method 1 offers ease of fixing whilst Mounting Method 2 can be used where more effective use of the FireRaptor's onboard temperature sensing is required, by placing the FireRaptor in position against the underside of the PV panel (or the surface where the temperature needs to be sensed). Once mounted ensure that the FireRaptor is secure.



The FireRaptor is housed in a plastic enclosure therefore grounding of the product is unnecessary.

Connect the two PV panels in series (typical wiring example below). Connect the array Positive (+) output connector to the FireRaptor Positive (+) input connector. Connect the array Negative (-) output connector to the FireRaptor Negative (-) input connector.

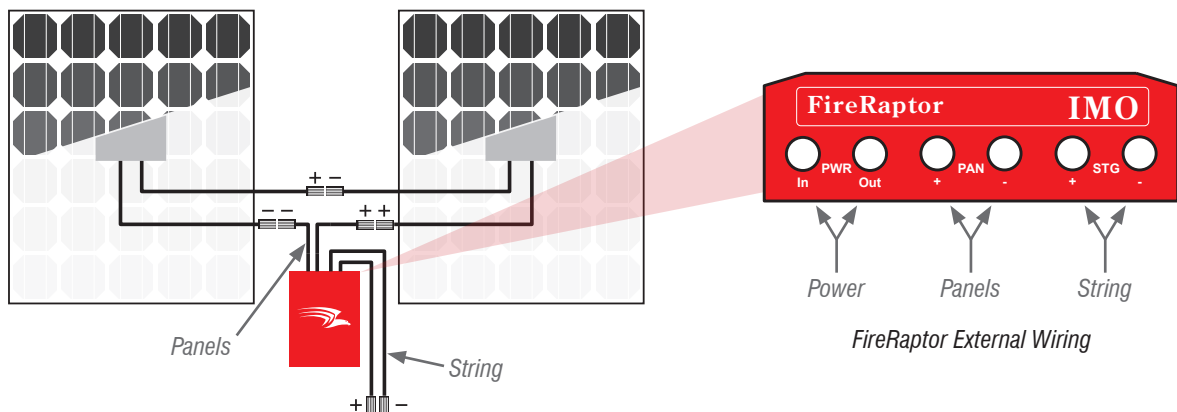

Warning – Ensure that you have identified the inputs correctly. The FireRaptor input cables are the shorter ones.

Connect the FireRaptor's two output cables to the DC isolator/Solar Inverter ensuring that the correct polarity is maintained throughout the electrical wiring.



The FireRaptor is OFF giving no array output until such time as the external DC power supply is energised and the Emergency Switch is in its non-activated position.

The Emergency Rapid Shutdown Switch Unit (FRS-ESW1 / FRS-ESW2 / FRS-ESW1-K / FRS-ESW2-K), hereafter referred to as FRS-ESW1, for installation; can be conveniently located anywhere for emergency access and is supplied with an internal 24VDC power supply to interface with the FireRaptor units.

Locate a convenient position for mounting the FRS-ESW1 unit ensuring that mains power connection is also available.

Remove the FRS-ESW1 cover and insert cable glands into position, ensuring that the sealing washer is between the main gland body and the outer enclosure surface, then tighten the securing/locking nut. Take care not to damage the switch, DIN terminals, power supply or wiring contained within the FRS-ESW1 enclosure.

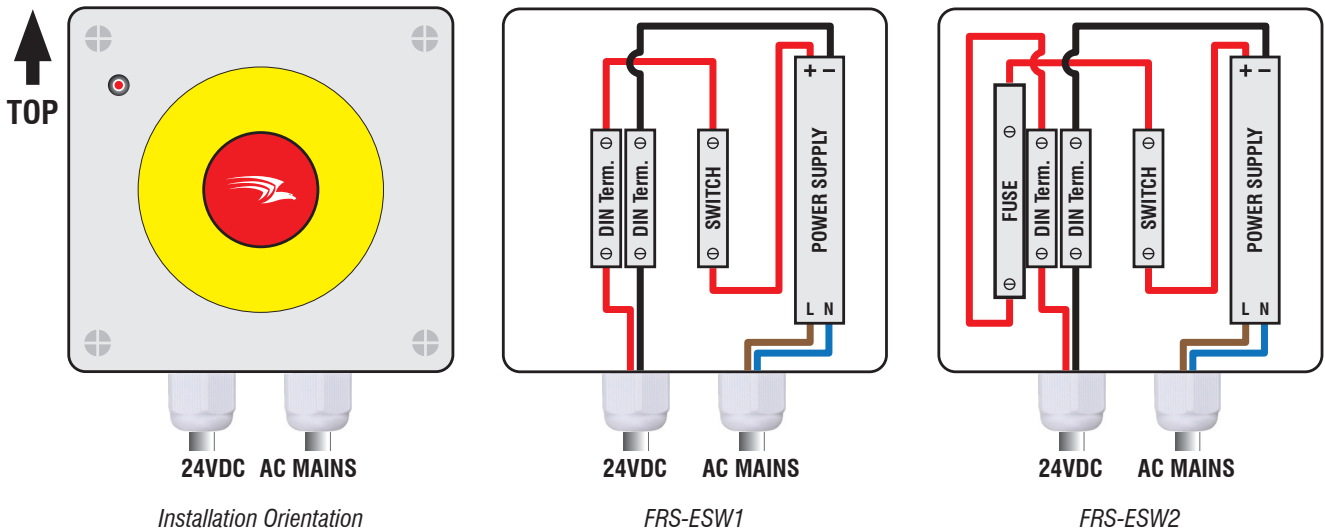

Using appropriate fixings attach the FRS-ESW1 unit vertically to the chosen surface.



Mounting the FRS-ESW1 non-vertically will invalidate warranty.

Connect the mains supply wire to the FRS-ESW1 power supply L and N (Live and Neutral) terminals using suitably rated 2-core cable (refer Technical Specifications section for electrical details) ensuring correct polarity of connections. Verify secureness of cables.



Strip AC mains wire length 4-5mm. Terminal tightening torque 0.5Nm (5lb-in).



Power Supply can be unclipped from the DIN-Rail for easier wiring.

Connect suitably rated 2x1mm² cable, one wire to the black wired DIN terminal Negative (-) terminal and with other wire to the red wired DIN terminal; this will be 24VDC Positive (+) wire. Terminate the remote end with a Tyco SuperSeal 2-pole socket (female) ensuring correct polarity of connections [Tyco connector: pin 1 Positive (+24VDC), pin 2 Negative (0VDC)].



Strip 24V DC wire length 10mm. DIN terminal tightening torque 0.5Nm (5lb-in).



Do not remove wire links connected within the FRS-ESW1. Verify screw tightness in case of loosening in transit.

Connect the Tyco SuperSeal 2-pole socket (female) to the FireRaptor plug (male).



Warning – Do not turn ON mains voltage until installation of FRS-ESW1 is completed and verified.

MULTIPLE INSTALLATIONS

One FireRaptor FRS-01 / FRS-02 will control two solar panels and by series connection of the FireRaptor, multiple solar panel pairs can be connected to form a greater capacity system. The diagram below illustrates a typical example of a FireRaptor protected 2kW installation using eight 250W solar panels and four FRS-01 FireRaptors.

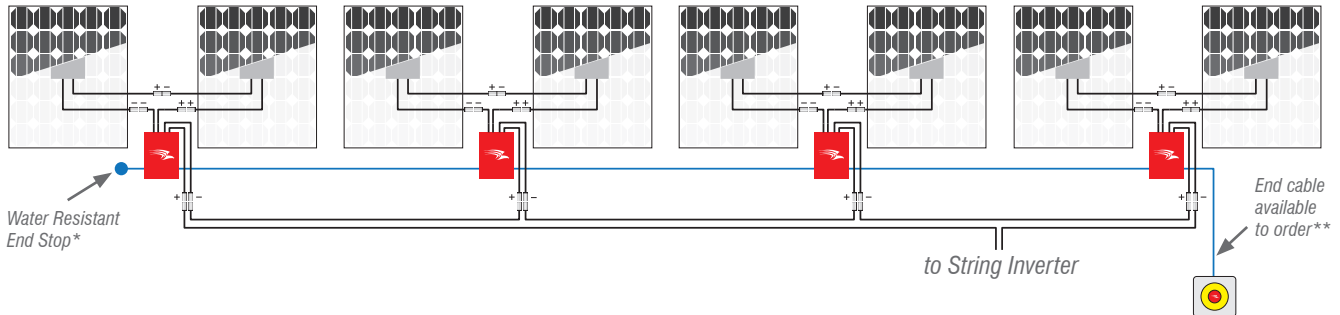

If the array has an odd number of panels, a single panel can be connected directly to the positive (+) and negative (-) panel cables of the FireRaptor.

Also, the IMO FireRaptor system allows for multi-level/multi-zone installation through the use of an Emergency Switch Enclosure (FRS-ESW1 plus FRS-AWS1) connected in series with the initial Emergency Rapid Shutdown Switch's power supply Positive (+) wire 24VDC.

* Water resistant end stop - Insert the two red sealing plugs in to the Tyco Superseal plug (supplied) and connect to the DC output connector of the last FireRaptor (FRS-01) in the series installation. If only a single FireRaptor (FRS-01) is used then this part is still used to seal the DC output connector.

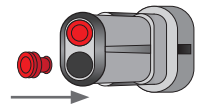

** A 1.8m flying lead terminated at one end with a Tyco female connector is available to order under part number FRS-SIGCAB1.8-F

OPERATION

Upon correct mounting and connection of the FireRaptor to the solar panels and the Emergency Shutdown Switch; and the turning ON of the mains supply, the FireRaptor will be operational.

1. Automatic Emergency Shutdown

- Should the FireRaptor (FRS-01) onboard temperature sensor detect an elevated ambient temperature rise in excess of 85°C then the FireRaptor will instigate an Automatic Rapid Shutdown thereby disabling the PV array output. Should the ambient temperature then drop back to below 85°C, the FireRaptor will re-engage the PV array output.
- In the event that the temperature exceeds 92°C then the FireRaptor (FRS-01) will only re-engage the solar panels by a manual reset done via the Emergency Shutdown Switch (refer to point 4a below).
- With FireRaptor FRS-02, should the onboard temperature sensor detect an elevated temperature in excess of 92°C then, like point (a), the FRS-02 will instigate an Automatic Rapid Shutdown thereby disabling the PV array output. Operation will only be recommenced by a manual reset done via the Emergency Shutdown Switch (refer to point 4b below)

2. Manual Shutdown

Upon the user operating the red push button switch located in the Emergency Switch Enclosure the FireRaptor performs a Rapid Shutdown, disabling the PV array output.

3. Utility Shutdown

Should there be a necessity by the emergency services for local or area utility grid shutdown the IMO FireRaptor will perform a Rapid Shutdown disabling the PV array output.

4. Reset

- On the occurrence of operation 1b (above) where the temperature exceeds 92°C, once the area is deemed safe, the FireRaptor FRS-01 is reset by operating the Emergency Shutdown Switch and then releasing this switch.
- Upon occurrence of operation 1c (above), the installation and FireRaptor FRS-02 units must be checked by a competent person. Once the area is deemed safe then the FireRaptor is reset by replacement of the appropriate fuse within the FRS-ESW2/FRS-ESW2-K and then operating the Emergency Shutdown Switch and then releasing this switch.



The Emergency Shutdown Switch is a typical “one push” large red emergency push button which requires an anti-clockwise twist to release.



The FRS-ESW1 and FRS-ESW1-K includes an LED status indicator which when used with FRS-01 signifies 24VDC power status (ON) or power loss (OFF).



The FRS-ESW2 and FRS-ESW2-K includes an LED status indicator which when used with FRS-02 signifies 24VDC power status (ON), or power loss or trip (OFF).

TECHNICAL SPECIFICATION

FRS-01 FireRaptor Unit

| | |
|-------------------------------|---|
| Emergency Shutdown Cable | 2x1mm ² cable + Tyco SuperSeal 2-pole plug/connector (male/female) |
| DC Power Supply* | 24VDC suitable for up to 20 FireRaptor units (40 panels) |
| Maximum Input Power | 700W (350W per panel) |
| Maximum Input Voltage | 150V (75V per panel) |
| Maximum Input Current | 12A |
| Maximum System Voltage | 1500V |
| Input Protection | Over voltage & transient voltage suppression |
| Maximum Output Current | 12A (99.5% efficiency) |
| Breakdown Voltage | 1500VAC for 1 minute |
| Maximum Output Voltage | 150V (75V per panel) |
| Output Protection | Over voltage, over current & transient voltage suppression |
| Ambient Operating Temperature | -30°C to +95°C |
| IP Class Protection | >IP68 (designed to comply with NEMA 4X) |
| Casing | Flame retardant Polycarbonate - UL94-V0 (f1) |
| Weight (without cables) | 300g |
| Panel Cable Length | 120mm |
| String & Signal Cable Length | 1800mm |
| Standard Compliance | EN 61000, EN 61646, EN 61215, IEC 62716 draft C (NH ₃ resistant), VDE-AR-E 2100-712, BS 7671-712 |

FRS-ESW1 Power Supply**

| | |
|---|--|
| Rated Input Voltage | 90-264VAC |
| Rated Input Current (at I ₀ nom) | 200mA (V _i 115VAC)/ 135mA (V _i 230VAC) |
| Rated Input Frequency | 47-63Hz |
| Input Fuse | T1A (250VAC) |
| Rated Output Voltage | 24VDC |
| Rated Output Current | 420mA |
| Rated Output Power | 10W |
| Ambient Operating Temperature | -30 °C to +60 °C |

* FRS-ESW1/FRE-ESW1-K Rapid Shutdown Switch can be upgraded to suit larger installations. Contact IMO for more details.

** FRS-ESW2/FRS-ESW2-K includes a 250V 500mA F fuse, replace only with fuse of the specified type, current and voltage. Contact IMO for more details.

TROUBLESHOOTING

| Problem | Possible Cause | Possible Solution |
|----------------------------|---|--|
| Panel (pair) voltage is 0V | No mains supply (LED OFF) | Check area utility operational Check mains ON Check mains fuse |
| | FRS-ESW1 power supply failure (LED OFF) | Check mains voltage between L & N marked terminals Check 24VDC between + & - marked terminals |
| | FRS-ESW1 switch activated | Turn red actuator anti-clockwise to release button |
| | No FRS-ESW1 switch output (LED OFF) | Check 24VDC between switch out terminal & PSU – marked terminal |
| | Broken cable (LED OFF) | Check 24VDC between terminals of remote Tyco SuperSeal connector (pin 1 +24VDC\pin 2 0VDC) |
| | PV array not connected | Check all PV to FRS-01 / FRS-02 input connections |
| | Incorrect FRS-01 / FRS-02 polarity connection | Check PV array Positive (+) goes to FRS-01 / FRS-02 Positive (+) and PV array Negative (-) goes to FRS-01 / FRS-02 Negative (-) |
| | No FRS-01 / FRS-02 output | Replace FRS-01 / FRS-02 |
| PV Inverter input 0V | No DC isolator (if fitted) input | Check FRS-01 / FRS-02 output connections Check DC inputs to isolator |
| | DC Isolator (if fitted) OFF | Turn DC Isolator ON |
| String voltage too low | Incorrect FRS-01 / FRS-02 polarity connection | Check all PV array Positive (+) go to FRS-01 / FRS-02 Positive (+) and PV array Negative (-) go to FRS-01 / FRS-02 Negative (-) |

In the occurrence of a fire IMO recommend that all elements of the FireRaptor Rapid Shutdown system be assessed for operational suitability by a competent person prior to re-energising.