

FW-SHUNT250

Installation Instructions

The FW-SHUNT250 is designed to attach to a single FX where space is limited.

Note: Installation of this kit will partially cover the product label, requiring one of the shunt mounting screws to insert through the label to secure the shunt.

To install:

- Remove the DCC (DC cover) from the FX
- Remove ground screw lug
- Remove the nuts and washers from negative (black) DC terminal post.
- Attach the TBB to the shunt
- Align the shunt with the visible threaded hole on top of the FX Series Inverter/Charger
- Align the bus bar - the engraved "O" must face up - with the DC terminal post
- Insert both 10-32 X 1/2 machine screws as shown in the illustration and tighten to the FX
- Attach the bus bar to the shunt and slide over the negative DC terminal post
- Reinstall the DC terminal post nut and washer and tighten over the bus bar

Note: tighten all machine screws to 14 inch-pounds

Parts Kit includes:

- (1) Terminal Bus Bar (TBB) to attach to the FW-SHUNT250
- (1) 500 amp/50 MV Shunt
- (1) Bus Bar
- (2) 10-32 X 1/2 stainless steel machine screws
- (2) 10-32 X 5/8 brass machine screws

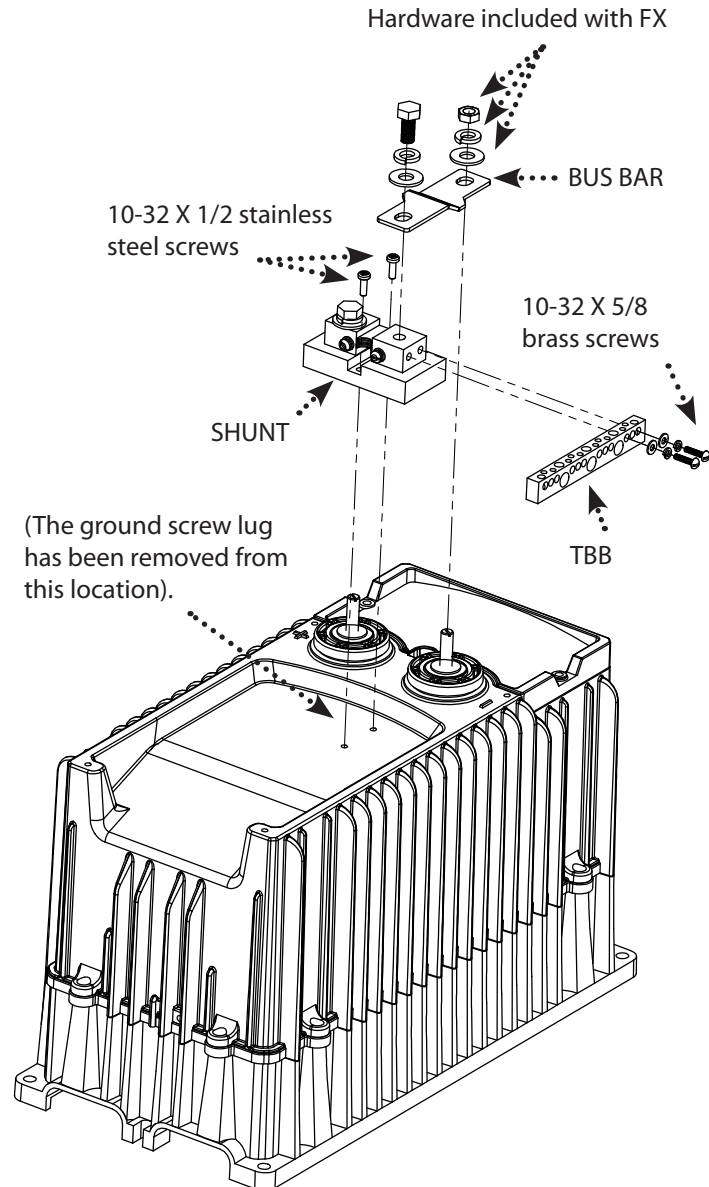

Note: The FW-SHUNT250 cannot be used on sealed FX units when a Turbo cooling fan is installed.